

# General Safety Information

## WARNING – To avoid serious injuries:

- SPD-SL pedals are designed so that you release them only when you intend to release. They are not designed to release automatically at times such as when falling off the bicycle. This is a safety measure to prevent you from losing balance and falling off the bicycle as a result of your feet becoming accidentally released from the pedals.
- Use only SPD-SL shoes with this product. Other types of shoes may not release from the pedals, or may release unexpectedly.
- Use only Shimano cleats (SM-SH10/ SM-SH11) and tighten the mounting bolts securely to the shoes.
- Before attempting to ride with these pedals and shoes, make sure you understand the operation of the engagement / release mechanism for the pedals and cleats (shoes).
- Before you attempt to ride with these pedals and shoes, apply the brakes, then place one foot on the ground and practice engaging and releasing each shoe from its pedal until you can do so naturally and with minimal effort.
- Ride on level ground first until you become adept at engaging and releasing your shoes from the pedals.
- Before riding, adjust the spring tension of the pedals to your liking.
- When riding at low speed or when there is a possibility that you might need to stop riding, (for example, when doing a U-turn, nearing an intersection, riding uphill or turning a blind curb), release your shoes from the pedal beforehand so that you can quickly put your feet onto the ground at any time.
- Use a lighter spring tension for attaching the pedal cleats when riding in adverse conditions.
- Keep cleats and bindings clear of dirt and debris to ensure engagement and release.
- Remember to check the cleats periodically for wear. When the cleats are worn, replace them. Always check the spring tension after replacing the pedal cleats and before riding.
- Be sure to attach reflectors to the bicycle when riding at night. Do not continue riding the bicycle if the reflectors are dirty or damaged, otherwise it becomes more difficult for oncoming vehicles to see you.
- Obtain and read the service instructions carefully prior to installing the parts. Loose, worn, or damaged parts may cause serious injury to the rider. We strongly recommend only using genuine Shimano replacement parts.
- If you have any questions concerning your pedals, contact a professional dealer.
- Read these Technical Service Instructions carefully, and keep them in a safe place for later reference.

### BE SURE TO READ AND FOLLOW THE ABOVE WARNINGS CAREFULLY.

- If the warnings are not followed, your shoes may not come out of the pedals when you intend or they may come out unexpectedly or accidentally, and severe injury may result.

### NOTE:

- Check that there is no looseness in any joints or connections before riding the bicycle. (BB-FC, FC-PD)
- In addition, if pedaling performance does not feel normal, check this once more.
- Parts are not guaranteed against natural wear or deterioration resulting from normal use.
- For maximum performance we highly recommend Shimano lubricants and maintenance products.

SI-42V0D

**PD-7800  
PD-6610  
PD-R540**

SPD-SL Pedals

## Technical Service Instructions

### Cleat types and using the pedals

#### ■ Cleat types

SM-SH10 (Option) Wide	SM-SH11 Narrow
<b>Fixed mode</b> There is no play when the shoes are firmly engaged with the pedals.	<b>Self-aligning mode</b> There is some sideways play when the shoes are firmly engaged with the pedals.

#### ■ Engaging the cleats with the pedals

Press the cleats into the pedals with a forward and downward motion.

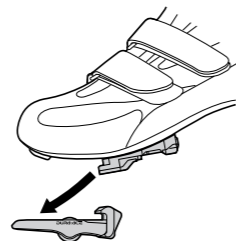

#### ■ Releasing the cleats from the pedals

Release the cleats from the pedals by twisting your heels outward.

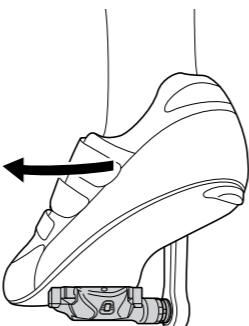

#### Note:

Place one foot on the ground, apply the brakes, and practice engaging and releasing the cleat from the pedal several times to determine the spring tension you prefer.

### Attaching the cleats

Set the cleat on the bottom of each shoe as shown in the illustration, and then provisionally tighten the cleat mounting bolts. Refer to the service instructions provided with your shoes for further details.

#### Note:

When installing the cleats, use the cleat mounting bolts and the cleat washers that are provided with the cleats. If you use any other cleat mounting bolts, it may damage the cleats and cause problems with correct installation.

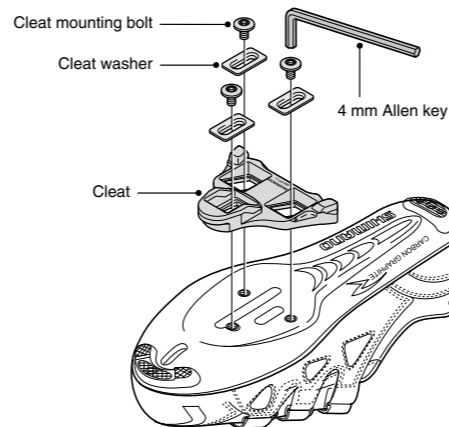

### Adjusting the cleat position

- The cleats have an adjustment range of 15 mm front to back and 5 mm right to left. After provisionally tightening the cleats, practice engaging and releasing, one shoe at a time. Readjust to determine the best cleat positions. Adjustment can also be carried out with the shoes already attached to the pedals.
- After you have determined the best cleat position, firmly tighten the cleat mounting bolts with a 4 mm Allen key.

**Tightening torque:**  
5 – 6 N·m {43 – 52 in. lbs.}

### Mounting the pedals on the crank arms

Use an 8 mm Allen key (for PD-7800 pedals) or a 15 mm spanner (for PD-6610 / PD-R540 pedals) to mount the pedals on the crank arms. The right pedal has a right-hand thread; the left pedal has a left-hand thread.

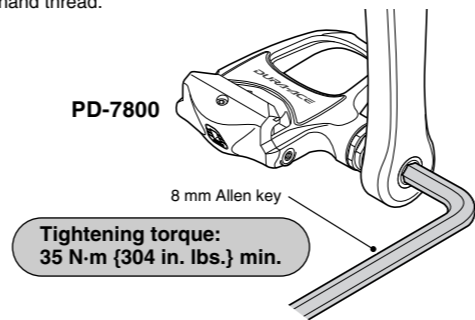

**Tightening torque:**  
35 N·m {304 in. lbs.} min.

**Pay attention to the mark**  
R: right pedal  
L: left pedal

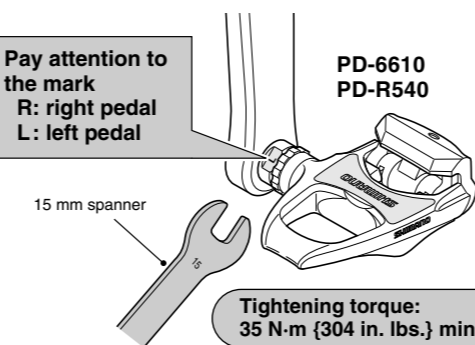

**Tightening torque:**  
35 N·m {304 in. lbs.} min.

### Adjusting the spring force of the binding

The spring force is adjusted by means of adjustment bolts at the rear of the pedals. Face the cleats in the direction of release when making this adjustment. Equalize the spring tensions for both pedals by referring to the tension indicators and by counting the number of turns of the adjustment bolts. The spring tensions can be adjusted in four steps for each turn of the adjustment bolts, and each adjustment bolt can be turned up to three full turns.

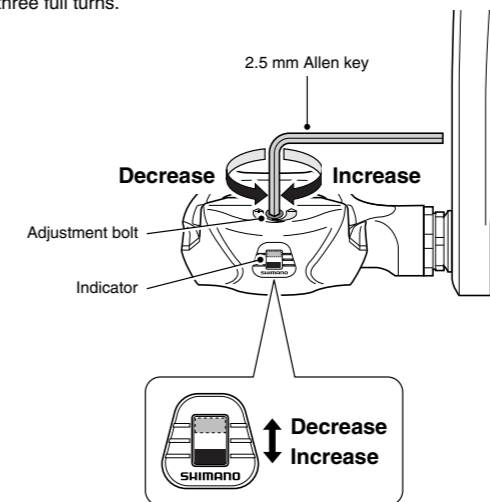

Do not turn the bolt past the point at which the indicator shows the maximum or minimum tension.

#### Note:

- Adjusting the spring force can help to prevent accidental release.
- The spring tensions should be equal for both pedals.
- If the spring tensions are unequal, a different amount of effort will be required to engage and release the cleats from the right and left pedals. This may make it difficult to engage and release the cleats.
- If the adjustment bolt is completely withdrawn from the spring plate, disassembly and reassembly will be required. If this occurs, ask a professional dealer for assistance.

### Cleat replacement

Cleats wear out over time and must be replaced. Replace your cleats when you find it difficult to engage or release.

## WARNING

**If you do not maintain your shoes and cleats in good condition, your shoes may not come out of the pedals when you intend or they may come out unexpectedly or accidentally, and severe injury may result.**

#### Note:

If the yellow (SM-SH11) or red (SM-SH10) portions of the cleats become worn, replace the cleats with new ones.

Front: Replace the cleats when the black layer underneath the cleats are visible.  
Rear: Replace when section A in the illustration becomes worn.

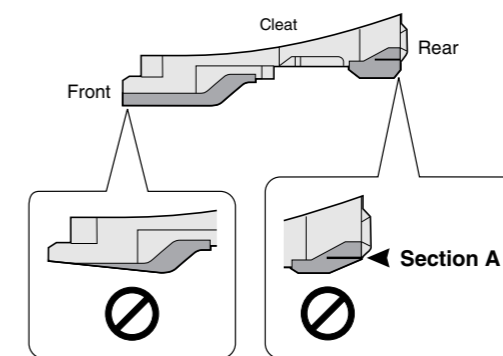

### Replacement of the body cover

If the body cover of the pedal becomes worn, replace it with the accessory body cover as shown below. (The body cover of PD-R540 is sold separately.)

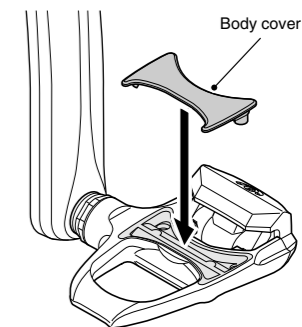

#### Note:

The body cover is a consumable part. Replace the body cover with a new one before any part of the body cover becomes flush with the pedal. If you continue to ride the bicycle without replacing the body cover, it may damage the pedal.

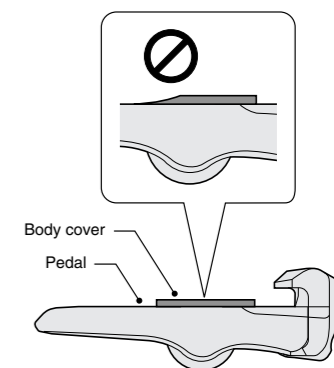

### Maintenance of the axle units

If you experience any trouble with the rotating parts of the pedal, the pedal may require adjustment. Obtain advice from a professional dealer.

### Mounting the reflectors (optional)

An optional reflector set (SM-PD58) is available. Please contact a professional dealer for details.

These service instructions are printed on recycled paper. Please note: Specifications are subject to change for improvement without notice. (English)

# SHIMANO

SHIMANO AMERICAN CORPORATION  
One Holland, Irvine, California 92618, U.S.A. Phone: +1-949-951-5003

SHIMANO EUROPE B.V.  
Industrieweg 24, 8071 CT Nunspeet, The Netherlands Phone: +31-341-272222

SHIMANO INC.  
3-77 Oimatsu-cho, Sakai, Osaka 590-8577, Japan